

4. Carburetor heat – OFF.
5. Retract flaps.
6. Execute normal go-round.

A power-off tail-low touchdown attitude is the best assurance of a porpoise-free landing, and excessive touchdown speed is not required with direct crosswinds up to 15 MPH. Use normal crab or wing-low side-slip landing approach techniques under these conditions.

**Short-Field Landing:** When making a landing where obstacle clearance or ground roll is a factor, the Yankee should be trimmed to an approach speed of 78 MPH with flaps fully extended. Touchdown should be made on the main gear at the slowest safe airspeed, and the brakes lightly checked for effectiveness immediately. If brakes do not respond, GO AROUND and proceed to another airport with longer runways. After touchdown, lower the nose, apply brakes, and retract the flaps. Use braking as necessary while holding the control wheel full back to increase brake effectiveness.

**Soft-Field Landing:** For soft fields, the Yankee should be trimmed to an approach speed of 78 MPH with flaps fully extended. Use power as necessary to control glide path and rate of descent, and use the shallowest possible glide path consistent with existing conditions. Touchdown in a rough or soft field should be in a nose-high pitch attitude at the slowest safe airspeed. The Yankee's nose wheel should be held off the surface as long as possible, and braking should be the *minimum* required for directional control and safety. (Maximum braking on soft surfaces may lead to excessive gear loads.)

**Balked Landings (Go-Arounds):** Should a landing be balked, apply full power immediately; carburetor heat OFF; establish a positive rate of climb; and retract the flaps.

**Slips to Landings:** Slips are very effective in the Yankee. Rapid descents with high sink rates can be obtained through a properly executed slip. It is recommended, however, that slips be practiced at altitude until the pilot is familiar with the high response of the Yankee. It is then recommended that full slips be limited to 500 feet AGL or above until the pilot is proficient with the Yankee. The recommended slip speeds for the Yankee are 80 to 85 MPH, depending on load, pilot proficiency, and local conditions. *Pilots should make themselves familiar with the Yankee at a variety of slip speeds.*

**Ground Handling and Tie-Down:** Yankee is easily handled on the ground by hand or with the aid of a tow bar attached to the nose wheel fork. Tie-down rings are provided under each wing tip and under the tail. Proper tie-down is the best insurance against damage to the airplane by gusty or strong winds, as evidenced by the Yankee's ability to ride out California's famous Santa Ana winds which exceed 75-80 MPH ... frequently. Installation of the control wheel lock helps avoid damage to the movable surfaces under such conditions. *In most circumstances, the control wheel should be locked in the forward position.*

Care should be taken when using the parking brakes for an extended period during which air temperature may rise. Such a temperature rise causes the hydraulic fluid to expand, which could damage the brake system and/or cause difficulty in releasing the parking brake. For prolonged parking, tie-downs and wheel chocks are preferred.

## Section IV

### Operating Limitations

The Yankee is approved for day VFR operation with standard equipment installed. With appropriate optional equipment installed, the Yankee is certified for day and night VFR and IFR. Operation must be in accordance with all FAA approved markings, placards and check lists in the airplane.

**Normal Category Operation:** The normal category is limited to airplanes intended for non-acrobatic operation within the flight load factor limitations listed below. The Yankee is approved for the following normal category maneuvers:

1. Any maneuver incident to normal flying.
2. Stalls (except whip stalls); and
3. Lazy eights, chandelles, and steep turns in which the angle of bank is not more than 60°.

Maximum Design Weight	1500 LBS
Design Maneuvering Speed	125 MPH – CAS
Flight Load Factors – Flaps Up	+3.8-1.52
Flaps Down	+2.0

**Utility Category Operation:** The utility category is limited to airplanes intended for limited acrobatic operation within the flight load factor limitations listed below. The Yankee is approved for the following utility category maneuvers:

1. All maneuvers listed under normal category operation; and
2. Lazy eights, chandelles, and steep turns, in which the angle of bank is more than 60°.

Maximum Design Weight	1430 LBS.
Design Maneuvering Speed	132 MPH – CAS
Flight Load Factors – Flaps Up	+4.4-1.76
Flaps Down	+2.0

#### Acrobatic Limitations:

Maneuver	Entry Speed – CAS
Chandelles	132 MPH
Lazy Eights	132 MPH
Steep Turns	132 MPH
Stalls (except whip stalls)	Slow deceleration
Spins Prohibited	

#### Spins are Prohibited:

In the event of an inadvertent spin, use the following recovery technique with *brisk* application of anti-spin controls:

1. Simultaneously apply full down elevator and full rudder opposite to the spin rotation while neutralizing the aileron.
2. Hold anti-spin controls until rotation stops.
3. When rotation has stopped, neutralize the anti-spin rudder and elevator.



then apply smooth elevator back pressure to bring the nose up to a level flight attitude.

**NOTE:**  
*If recovery controls are not briskly applied in the first turn, more than one additional turn will be required for recovery. For quick recovery, apply full anti-spin controls as the spin begins, before one turn is completed.*

**Airspeed Limitations:**  
 Maximum Glide or Dive, Smooth Air (red line) 195 MPH - CAS  
 Caution Range (Yellow Arc) 144-195 MPH - CAS  
 Normal Range (Green Arc) 69-144 MPH - CAS  
 Flap Operating Range (White Arc) 66-100 MPH - CAS  
 Maneuvering Speed - Normal Category 125 MPH - CAS  
 Utility Category 132 MPH - CAS

**Engine Instrument Markings:**  
 Oil Temperature Gauge - Normal operating range 245°F. (Red Line) Green Arc  
 Maximum allowable 25 PSI  
 Oil Pressure Gauge - Minimum idling 60-90 PSI  
 Normal operating range 100 PSI  
 Maximum

**Fuel Quantity Indicators -**  
 Empty (1 gallon UNUSEABLE each tank) 0 (Red Area)  
 Tachometer - Normal operating range 2000-2600 RPM

**Weight and Balance:** In order to facilitate computation of the weight and balance of a particular Yankee, an example is given on page 23. All procedures for use of the charts are outlined in the weight and balance section. Remember, always refer to the weight and balance of the Yankee you are flying - variations do exist from aircraft to aircraft. The data given here is for a sample aircraft only. Add all applicable weights together in one column and total up the moments in the other. For convenience, a loading graph is provided giving the moment for each item.

Refer to the center of gravity envelope on page 21. Find the intersection of the total weight and moment on the graph. If this point is within the envelope, the loading is acceptable.

**NOTE**  
 The operating limitations of this airplane include SPINS PROHIBITED. A spin is not possible without a prolonged stall condition. All types of stalls (except whip, which are prohibited) can be performed in this airplane without spinning by simply recovering from the stall when it occurs (moving the control wheel forward sufficiently to reduce angle of attack for normal forward flight).

There is evidence that permitting a spin to go beyond one turn without initiating proper recovery procedures can allow a spin mode to develop from which recovery is not possible.

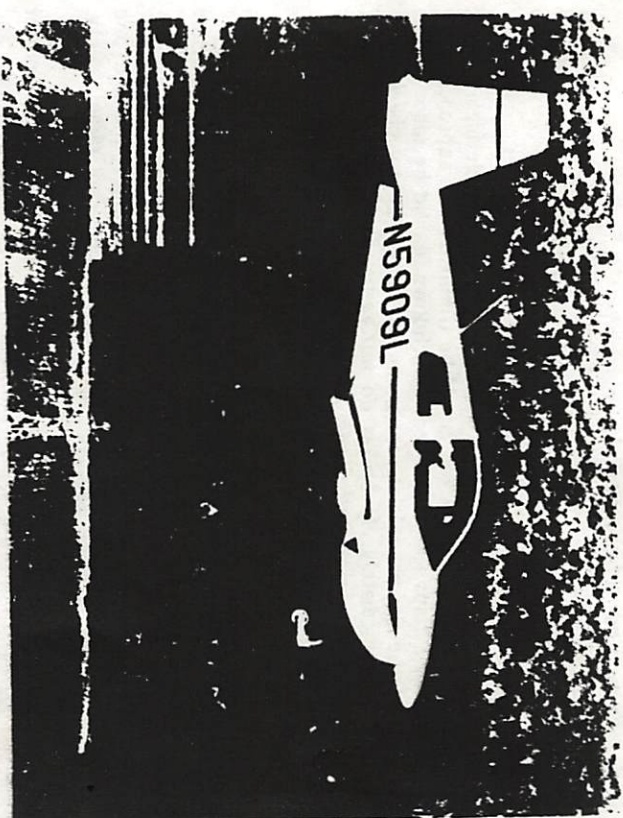

Figure 8. Yankee's visibility is excellent for sight-seeing.

**Normal Approach and Landing:** The Yankee should be trimmed to an approach speed between 80 and 90 MPH, depending on weight and wind conditions. Normal approach speed is 85 MPH. Maximum flap extension speed is 100 MPH. Any flap setting may be used for landings.

As a general rule, it is good practice to contact the ground at a minimum safe speed consistent with existing conditions. After touchdown, hold the nose wheel off as long as possible on roll-out. Lower the nose gently and apply brakes as needed. Retract the flaps after touchdown to minimize the possibility of skidding when braking. In gusty or crosswind conditions, many pilots prefer to increase their airspeed slightly above the normal approach speed; this decision, however, can only be made by the pilot in the light of his own experience and training.

**NOTE:**  
*A pilot-induced porpoise maneuver may be entered during landing by contacting the nose wheel first with excessive touchdown speed. The porpoise could be accentuated by a wavy or rolling runway surface. Should a porpoise occur, use the following technique to recover:*

1. Apply full power.
2. Maintain steady elevator-back pressure for a normal climb.
3. Normal climb - 95 MPH.



gross weight, sea level, is 89 MPH. Best angle of climb at gross weight, sea level, is 78 MPH and should be used for obstacle clearance. Refer to Section V Performance Charts for additional information.

**NOTE:**

The mixture should be full rich during take-off and climb at altitudes below 5000 feet MSL. However, during take-off or climb from high-altitude airports, the engine should be leaned to achieve best power (maximum RPM).

**Cruise:** The maximum recommended cruise power setting for the Yankee is 75% of the rated horsepower. True airspeeds, which are determined by the particular altitude and power setting chosen, can be obtained from the tables in Section V.

Fuel consumption can be reduced significantly, especially at high altitudes, by leaning the mixture in cruising flight. For optimum fuel consumption in cruise at 75% power or less, lean the mixture as follows:

1. Slowly move the mixture control from full rich position toward lean position.
2. Continue leaning until engine roughness is noted.
3. Enrich mixture slightly until engine runs smoothly.

Continuous use of carburetor heat during cruising flight decreases engine efficiency, and is not recommended. Use carburetor heat only as necessary. When applying carburetor heat, do so slowly to the full-on position (and only for a few seconds) at intervals to determine if ice has developed.

**NOTE:**

If engine runs rough during cruise with carburetor heat on, it may be due to an overrich condition. To correct for engine roughness in such a situation lean to smooth engine operation.

To maintain a laterally trimmed condition in cruise, it is recommended that the fuel selector be changed approximately every 30 minutes. If flying alone, initial trim should be obtained by using from the left tank until approximately 1/2-tank of fuel is burned; this requirement may be eased, however, by judicious placement of baggage to the right of the baggage compartment.

**Stalls:** Yankee's stall characteristics are conventional in all configurations. Elevator buffeting occurs approximately 5 MPH above the stall and becomes more pronounced as the stall occurs. An audible stall warning horn begins to blow steadily 5 to 10 MPH above the actual stall.

The table below indicates stalling speed as a function of bank angle and flap setting at maximum weight and a forward center of gravity loading. Note that the stalling speed markedly increases with bank angles.

MODEL AA-1	
STALL SPEED - MPH CAS	
CONDITION	BANK ANGLE
	0° 20° 40° 60°
FLAPS UP	69 71 79 98
FLAPS DN	67 69 77 95
1500LBS POWER OFF	

Avoid uncoordinated use of the controls at the stalling speed as this may result in a spin. SPINS ARE PROHIBITED.

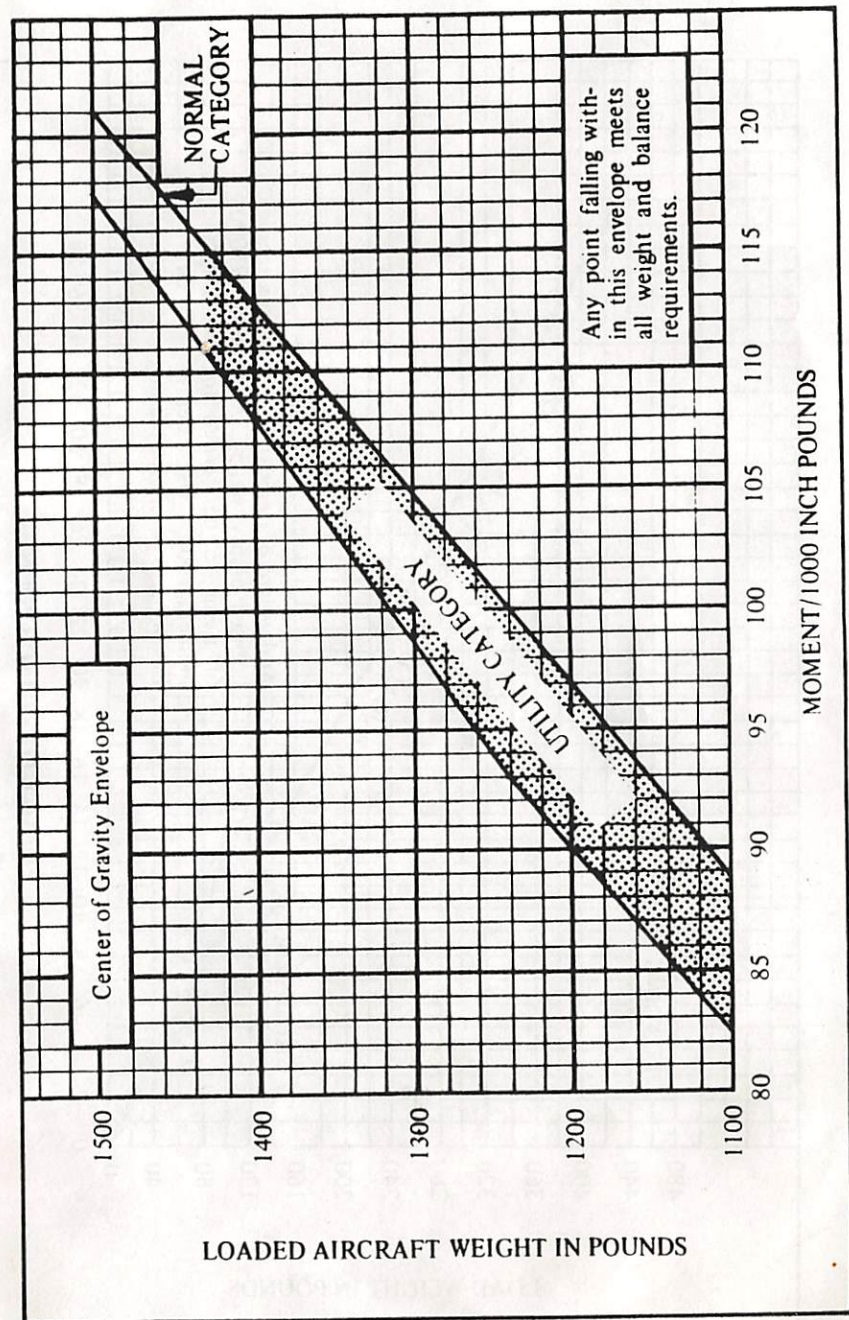



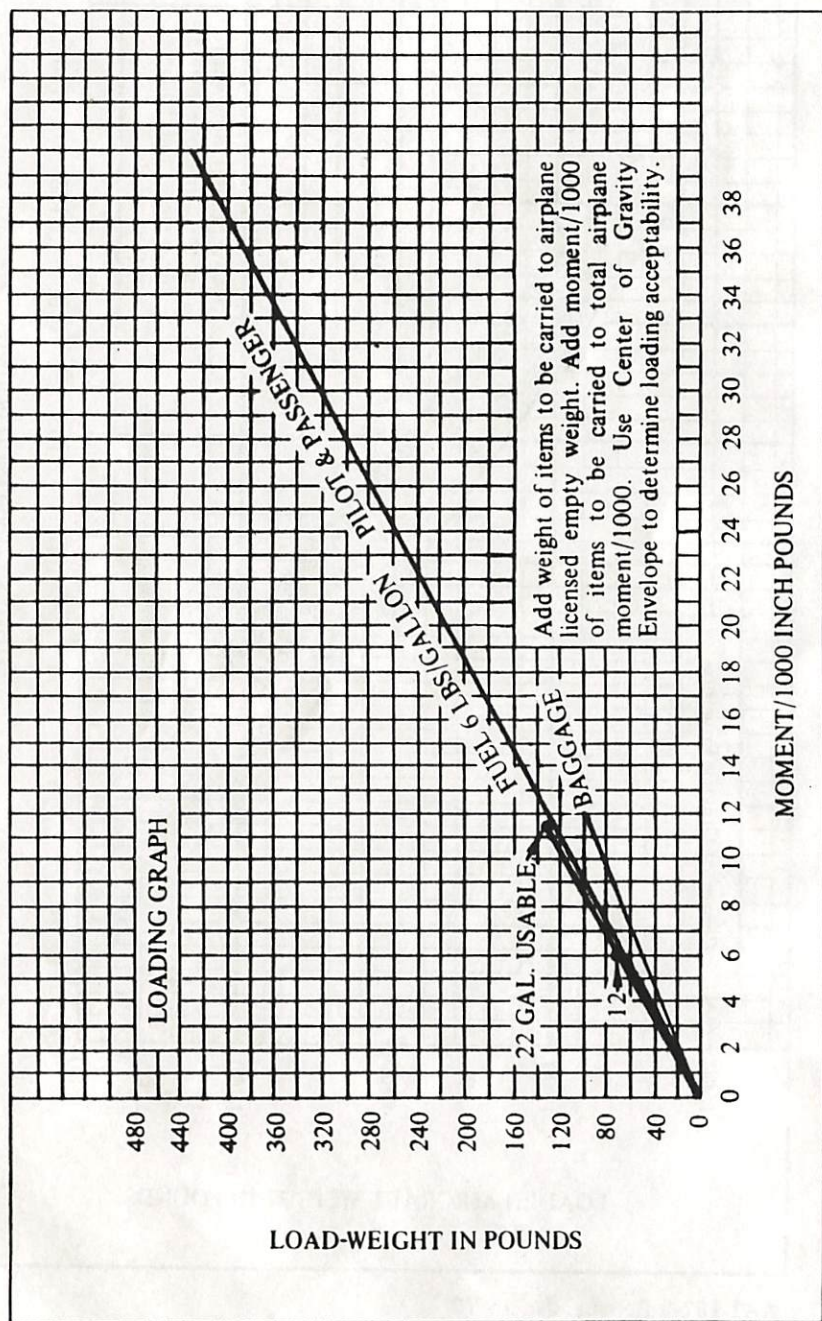

**Warm-Up and Ground Check:** Engine warm-up should be conducted at 800 to 1200 RPM. The magneto check is run at 1800 RPM using the BOTH-RIGHT-BOTH-LEFT-BOTH sequence. Maximum RPM drop per magneto should not exceed 125 RPM, or 50 RPM differential between magnetos. The carburetor heat should be checked for operation at this time, then returned to the full OFF position. The engine is ready for take-off when it will take full throttle without hesitating or faltering.

**Take-Off:** When full power is applied for take-off (approximately 2200 RPM), directional control is maintained with light toe-pressure on the brakes. At speeds above 15-20 MPH, Yankee's rudder becomes fully effective and brake steering is NOT necessary. (Continued use of brake steering will only prolong the take-off roll.)

Allow the Yankee to accelerate to 65-70 MPH before applying a light back pressure on the control wheel to lift off. Raising the nose wheel too soon or to an excessive angle may increase take-off ground distance. When airborne, accelerate to the desired climb speed.

**Soft-Field Take-Off:** If the surface is smooth, rut-free and wide enough for a gradual turn onto the runway, initiate the take-off with a rolling start as you taxi onto the runway. *Avoid sharp turns to prevent putting excessive side-loads on the landing gear.* Hold full back pressure as you taxi and as take-off roll is begun. This technique lightens any loads on the nose wheel. If the surface is marginal and/or too narrow for a gradual turn onto the runway, align the Yankee with the runway, apply full brakes, and build up take-off RPM before starting the take-off roll. (Do not prolong this run-up unnecessarily since the propeller will tend to pick up stones and debris that can put nicks in the propeller, etc.)

As you apply full power, move the control wheel to neutral and allow the Yankee to accelerate to 65-70 MPH. Lift off with a light back pressure. After lift-off, release enough of this back pressure to permit the Yankee to accelerate to its best angle- or rate-of-climb speed as required by obstructions.

**Short-Field Take-Off:** Short-field take-offs in the Yankee are best made with NO flaps and, if possible, from a rolling start as you taxi onto the runway. Move the elevator control wheel to the neutral position to accelerate to flying speed with the least ground roll. As airspeed builds to 60 MPH, add just enough back pressure to put the Yankee in a take-off attitude. As airspeed builds past 66 MPH, lift off and accelerate to the best angle of climb speed (78 MPH) until all obstacles have been cleared. Accelerate to the best rate of climb speed (89 MPH) until a safe altitude is reached, then accelerate to a cruise climb (about 95 MPH) for better engine cooling and better forward visibility.

**NOTE:**

*Speeds given are for gross weight, sea level conditions.*

**Climb:** A normal climb speed of approximately 95 MPH is recommended, once above ground obstacles. This speed offers improved visibility, better over-the-ground speed, and an excellent rate of climb. *Best* rate of climb at



## Section III Operating Procedures

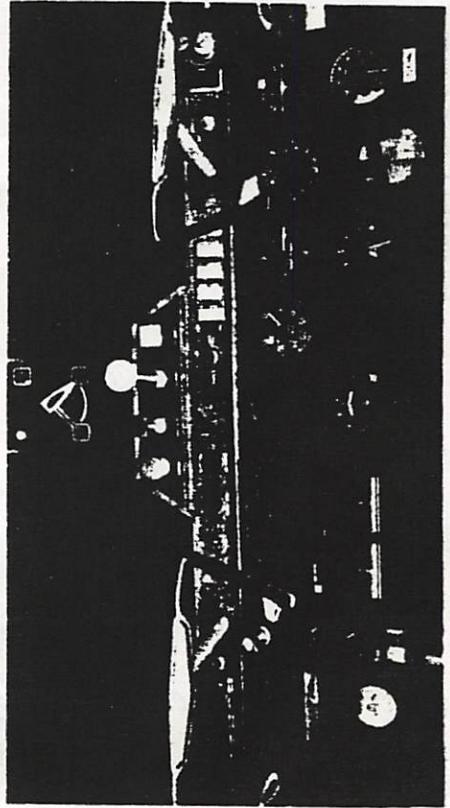

Figure 7. Typical Yankee instrument panel.

**Starting the Engine:** Before priming, set the parking brake by depressing the tops of both rudder pedals and pulling out the parking brake control knob. It is good practice to turn all radios and lights off, both to limit battery drain during the start and to protect avionics from voltage surges.

**NOTE:**

*Normally, one to three strokes of the priming pump is sufficient for quick starting. In temperatures below 40°F, however, four to six strokes may be necessary. During extremely cold days, starting will be aided by pulling the propeller through four or five revolutions by hand. Switches must be OFF when pulling the propeller. Preheating the engine or oil before starting in sub-zero temperatures, as in any aircraft, will speed the start and conserve the battery charge.*

With the parking brake set, clear the propeller area; set the mixture in the full-rich position; turn master switch ON; set ignition switch to LEFT; and engage the starter. If the engine fails to start on the first attempt, a second attempt should be made without priming. If the day is hot and the second attempt fails, it is possible that you have over-primed. Turn the ignition switch to OFF; open the throttle and turn the engine approximately ten revolutions with the starter. Prime the engine again with one-half the original prime and repeat the starting procedure. If the day is cold, it is more likely that the problem is under-priming. In this case, a few extra strokes of the primer should provide a prompt start. As soon as the the engine starts place ignition switch to BOTH.

Check the oil pressure as the engine starts. If no oil pressure is indicated within 30 seconds (60 seconds on very cold day), stop the engine and determine the source of trouble. Oil pressure should indicate approximately 25 psi with the engine at idle.

Sample Loading Problem	Sample Airplane			Your Airplane		
	Weight (lbs.)	Arm (in.)	Moment (lb.-in. /1000)	Weight (lbs.)	Arm (in.)	Moment (lb.-in. /1000)
1. Empty weight (licensed)	1007		74.492			
2. Oil (6 qts.) 1 qt. = 1.8 lbs.	11	39.0	.429		39.0	
3. Fuel (in excess of unusable)	132	84.5	11.154		84.5	
4. Pilot and Passenger	340	92.5	31.450		92.5	
5. Baggage (allowable 100 lbs.)	10	120.0	1.200		120.0	
6. Total Aircraft weight (loaded)	1500	79.1	118.725			
7. Locate this point (1500 at 118.725) on the Center of Gravity Envelope, and if the point falls within the Envelope, the above loading is satisfactory.						



## Section V

### Performance Charts

Performance information has been derived from actual flight tests and has been corrected to standard atmospheric conditions. Actual performance may vary from standard due to variations in atmospheric conditions, engine and propeller condition, mixture leaning technique, and other variables associated with the particular performance item.

Model AA-1 – Cruise Performance Table

Altitude Feet	RPM	Percent Power	True Air-speed MPH	Fuel Consumption GPH	Endurance Hours	Range Miles Zero Wind
2,500	2600	85	136	7.3	2.8	384
	2500	77	130	6.5	3.1	408
	2400	70	123	5.8	3.5	434
	2300	63	116	5.2	3.9	455
	2200	56	108	4.7	4.3	468
2100	49	96	4.3	4.7	458	
4,500	2600	82	135	6.9	2.9	399
	2500	75	129	6.2	3.3	425
	2400	67	122	5.5	3.7	452
	2300	60	114	4.9	4.1	467
	2200	53	104	4.5	4.5	472
2100	46	90	4.2	4.8	440	
6,500	2600	78	135	6.6	3.1	415
	2500	71	128	5.8	3.5	441
	2400	63	120	5.2	3.8	460
	2300	56	110	4.7	4.3	470
	2200	50	98	4.3	4.6	457
8,500	2600	74	133	6.2	3.3	429
	2500	67	126	5.5	3.6	453
	2400	60	117	5.0	4.0	466
	2300	53	106	4.5	4.4	465
10,500	2600	72	132	5.9	3.4	441
	2500	63	122	5.2	3.8	460
	2400	57	112	4.7	4.2	466

#### NOTES:

- 1) Range and endurance data include allowance for take-off and climb.
- 2) Fuel consumption is for level flight with mixture leaned to best power. Continuous operation at powers above 75% should be with full-rich mixture.
- 3) Speed performance data is with wheel fairings. Subtract 2 mph for cruise without wheel fairings.
- 4) For temperatures other than standard, add or subtract 1% power for each 10°F below or above the standard temperature; respectively.

- |                             |                                 |
|-----------------------------|---------------------------------|
| 1. Compass Card             | 17. Fuses & Circuit Breakers    |
| 2. Compass                  | 18. Cigar Lighter               |
| 3. Airspeed Indicator       | 19. Parking Brake Control       |
| 4. Turn-And-Bank Indicator  | 20. Cabin Heat Control          |
| 5. Gyro Horizon             | 21. Engine Primer               |
| 6. Directional Gyro         | 22. Mixture Control             |
| 7. Altimeter                | 23. Throttle Control            |
| 8. Vertical Speed Indicator | 24. Carb Heat Control           |
| 9. Tachometer               | 25. Instrument Light Rheostat   |
| 10. Omni Head               | 26. Individual Circuit Switches |
| 11. Radio                   | 27. Starter Switch              |
| 12. Instrument Cluster      | 28. Master Switch               |
| 13. Suction Gauge           | 29. Ignition Switch             |
| 14. Hourmeter               | 30. Phone Jack                  |
| 15. Glove Compartment       | 31. Clock                       |
| 16. Spare Fuses             |                                 |

#### Landing (Normal):

1. Touchdown on main gear.
2. Lower nose wheel slowly as speed decreases.
3. Directional control: Use rudder until it becomes ineffective (approximately 20 MPH).
4. Brakes: As required for stopping and directional control.

#### Landing (Obstacle Clearance):

1. Airspeed: 78 MPH.
2. Flaps: Fully extended.
3. Land on main wheels first.
4. Lower nose wheel.
5. Directional control: Use rudder until it becomes ineffective (approximately 20 MPH).
6. Flaps: UP.
7. Brakes: As required for stopping and directional control.

#### Balked Landing:

1. Apply full throttle.
2. Carburetor heat: OFF.
3. Establish climb attitude.
4. Flaps: Retract.

#### After Landing:

1. Flaps: UP.
2. Carburetor heat: OFF.
3. Auxiliary fuel pump: OFF.

#### Shut-Down:

1. All electrical equipment: OFF.
2. Mixture: To idle cutoff.
3. Magneto switch: OFF.
4. Master switch: OFF.
5. Install control lock.
6. Brakes: Set and/or wheels chocked.



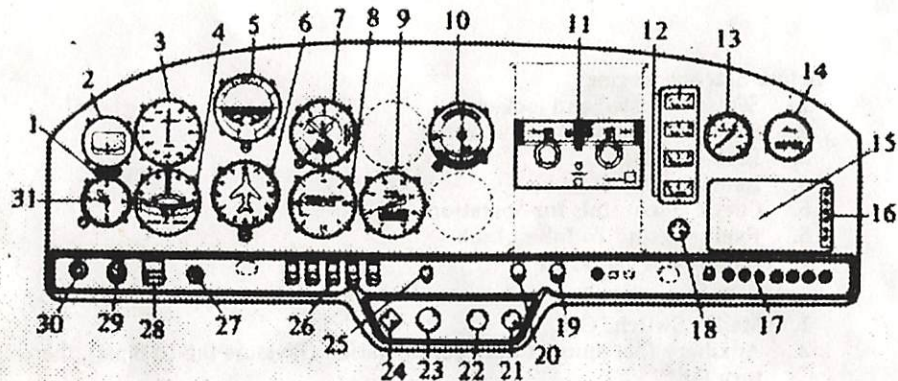

Figure 6. Yankee instrument panel diagram.

**Take-Off (Normal):**

1. Auxiliary fuel pump: ON.
2. Throttle: Full open.
3. Raise nose wheel between 65 and 70 MPH.
4. Normal climb speed: 95 MPH.

**Take-Off (Obstacle Clearance):**

1. Auxiliary fuel pump: ON.
2. Throttle: Full open.
3. Controls: Neutral, then lift off smoothly at 70 MPH.
4. Climb speed: 78 MPH (best angle of climb).

**Climb (Normal):**

1. Airspeed: 95-105 MPH.
2. Full Throttle.

**Cruise:**

1. Auxiliary fuel pump: OFF.
2. Power Setting: 2100 to 2600 RPM.
3. Mixture: Full rich when operating at more than 75% power. If in doubt as to percentage of power being used, use full-rich mixture for all operations below 5,000 feet.
4. To maintain best *fuel load balance*, change fuel selection at approximately 30-minute intervals during cruise. If flying solo, maintain the left tank about 1/2-tank lower than the right. This technique will substantially improve lateral trim.

**Before Landing:**

1. Fuel selection: To fullest tank.
2. Mixture: Full rich.
3. Auxiliary fuel pump: ON.
4. Carburetor heat: Check, leave ON if icing conditions are known to exist.
5. Airspeed: 80-90 MPH.
6. Wing flaps: As desired below 100 MPH.

Optional Propeller Data: An optional McCauley 1A105/SCM 7153 propeller is available for the Yankee. This "climb propeller" will increase the Yankee's rate of climb 75 ft./min., and will affect cruise performance in accordance with the following table

*To Obtain	Add	Speed Differential	Fuel Consumption
75% BHP	120 RPM	- 1.5 MPH	6.2 GPH
65% BHP	110 RPM	- 1.5 MPH	5.4 GPH
55% BHP	75 RPM	- 1.5 MPH	4.7 GPH

**Take-Off Distance To Clear 50 ft. Obstacle - Hard Surface Runway**

1500 Lbs. Gross Weight - Flaps Up; 78 MPH IAS

Altitude	Wind	Sea Level	2000 ft	4000 ft	6000 ft
Temperature	Knots	59°F	52°F	45°F	38°F
Ground Run	0	900	1030	1210	1400
Total Distance		1615	1910	2345	2960
Ground Run	10	635	735	870	1020
Total Distance		1235	1480	1840	2360
Ground Run	20	410	480	585	700
Total Distance		900	1090	1375	1805

**NOTE:**

- 1) Reduce both ground run and total distance by 25% at 1330 lbs. gross weight.
- 2) Increase ground run 7% for each 20°F above standard temperature.
- 3) The increase in total take-off distance varies from 8% at sea level to 14% at 6000 ft. for each 20°F above standard temperature.

**Maximum Rate-of-Climb Performance**

1500 Lbs. Gross Weight - Flaps Retracted

Altitude Ft.	Temperature °F	IAS MPH	Rate of Climb Ft./Min.	Fuel Used From Sea Level - Gals.
S.L.	59.0	89	710	0.5
2500	50.0	88	570	1.0
4500	42.8	87	460	1.5
6500	35.6	86	350	2.0
8500	28.4	85	240	2.6

**NOTES:**

- 1) Full-throttle climb, mixture leaned above 5000 ft. to smooth engine operation.
- 2) Fuel used includes taxi and warm-up allowance.



**Landing Distance To Clear 50 ft. Obstacle – Hard Surface Runway  
1500 Lbs. Gross Weight – Flaps Down; 78 MPH IAS Zero Wind**

Altitude	Sea Level	2000 ft.	4000 ft.	6000 ft.
Temperature	59°F	52°F	45°F	38°F
Ground Run	490	520	550	590
Total Distance	1240	1320	1400	1480

**Stall Speed Table – Power Off (MPH CAS)  
1500 Lbs. Gross Weight**

Condition		Bank Angle			
		0°	20°	40°	60°
Aft CG	Flaps – Up	66	68	76	94
Loading	Flaps – Down	65	67	74	92
Forward CG	Flaps – Up	69	71	79	98
Loading	Flaps – Down	67	69	77	95

**Airspeed Correction Table (MPH)  
1500 Lbs. Gross Weight – Flaps Up - Down**

IAS	60	70	80	90	100	110	120	130	140	150	160	170	180
CAS	61	71	80	90	100	110	119	129	139	148	158	168	178

**Before Starting Engine:**

1. Seats: Adjusted and locked.
2. Seat belts: Buckled and adjusted.
3. Brakes: Set.
4. Remove control lock.
5. Check all controls for operation.
6. Fuel selector: To fullest tank.
7. Radios and lights: OFF.

**Starting Engine:**

1. Master Switch: ON.
2. Auxiliary fuel pump; Check for operation (Pressure 0.5 to 8 psi), then turn OFF.
3. Mixture control: Full rich.
4. Prime engine: 1 – 3 strokes.
5. Carburetor heat: OFF.
6. Throttle: Open ¼ inch.
7. Clear Propeller.
8. Ignition switch: On LEFT.
9. Press starter button.
10. Ignition switch: On BOTH.
11. Check oil pressure. If no pressure indication in 30 seconds, shut engine down and determine trouble.

**Engine Run-Up:**

1. Throttle setting: 1800 RPM.
2. Engine instruments: Operating properly in green arc ranges.
3. Check magnetos: RIGHT-BOTH-LEFT-BOTH.  
125 RPM maximum drop on either magneto.  
50 RPM maximum differential between magnetos.
4. Carburetor heat: Operation checked for RPM drop.
5. Suction gauge (if installed): 4.6 to 5.4 inches Hg.
6. Radio (if installed): Operation checked.
7. Engine is ready for take-off when it will take full throttle without hesitating or faltering.

**Before Take-Off:**

1. Console Check:
  - a. Microphone (if installed): Secure.
  - b. Flaps: Check for correct operation.
  - c. Trim wheel: At take-off setting.
  - d. Fuel: On fullest tank.
  - e. Flaps: UP.
2. Panel and Control Check:
  - a. Primer knob: In and locked.
  - b. Mixture: Full rich.
  - c. Carburetor heat: OFF.
  - d. Auxiliary fuel pump: ON.
  - e. Controls: Free – no binding – movement in proper direction.
  - f. Flight instruments: Set.
  - g. Engine instruments: Normal.



## Section VI

# Emergency Procedures

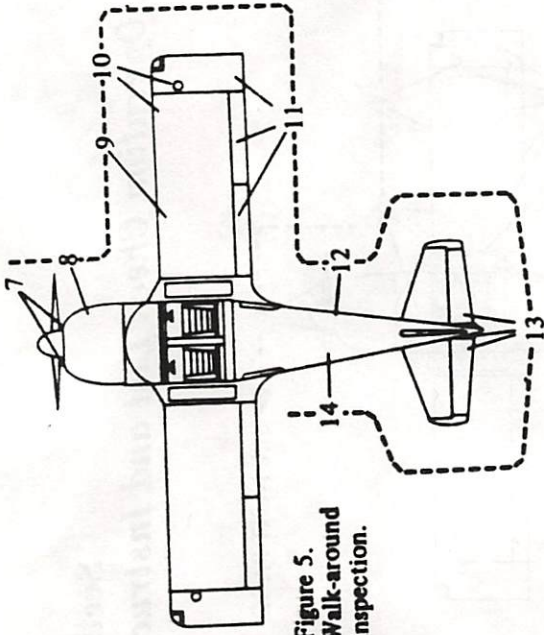

Figure 5.  
Walk-around  
inspection.

7. Engine baffles and cooling openings free of foreign materials/obstructions.  
Remove tow bar.

8. Check oil level. It is recommended you **DO NOT OPERATE ENGINE WITH LESS THAN 4 QUARTS. FILL TO 6 QUARTS FOR EXTENDED FLIGHT.**  
Check nose gear and tire for wear, cuts, abrasions, inflation.

9. Inspect landing gear and tires for general condition (wear, cuts, abrasions, leaking brakes, proper inflation).  
Fuel tank vent free of foreign material.

10. Secure fuel cap for tight seal.  
Check stall switch vane for freedom of movement.

11. Check ailerons for freedom of movement.

Check for flap security.

Check wing surface and tip for damage.

Remove right tie down.

Drain fuel sample from right wing.

12. Check static source for foreign particles.

13. Check elevators, rudder and trim tab for freedom of movement.

Check tail cone for security.

Remove tail tie down.

14. Check static source for foreign particles.

**NOTE:**

*For night operations: always check instrument, position and landing lights for correct operation prior to starting engine. Always carry a flashlight during night operations.*

**Brake Failure:** Although brake failure is infrequent in any aircraft, landing without brakes is no problem in the Yankee. If a brake failure is detected, proceed to the nearest airport with adequate runway length to accommodate an emergency brake-failure landing. It is recommended, with a single brake failure, that *neither* brake be utilized during landing and roll-out.

Plan your touchdown near the approach end of the runway. The aircraft's nose should be aligned with the runway centerline. Use minimum safe airspeeds for existing conditions. Maintain directional control straight down the runway with use of rudder only. Allow the aircraft to roll to a stop on the runway without the use of brakes. Prior to shutdown, request assistance from the appropriate ground control authority, then shut down the engine. It is recommended that towing to a parking area be accomplished with hand tow or "tug."

**Low Oil Pressure/Engine Overheat:** A low oil-pressure indication may be caused by a malfunction in the indicating system or an actual loss of oil. If a low-oil indication is detected, monitor the oil temperature gauge for a marked change. If no temperature change is detected, the failure is most likely in the oil pressure indicating system. Proceed to the nearest airport, land and visually check the oil level.

In flight, if the oil pressure indication is low *and* is confirmed by high oil temperatures, reduce power and proceed to the nearest airport or suitable landing area. If possible, notify the nearest ATC radio facility of your difficulty and land.

**REMEMBER:** A thorough and complete preflight will *usually* prevent low-oil-pressure emergencies.

**Electrical Systems Malfunction:** The ammeter system of the Yankee gives the pilot an immediate indication of alternator output (not of battery charge). During normal operation, the ammeter will show a typical continuous alternator output of 10 to 20 amperes. This is the actual current load drawn by the aircraft's electrical system. The majority of electrical malfunctions can be traced to either insufficient or excessive alternator output, which can be diagnosed as follows:

**Excessive Output:** If a sustained (30 minutes or more) high charge rate is noted, an electrical malfunction may exist. This can cause severe battery or electrical system damage. If this sustained high-output indication is observed, turn OFF all electrical systems to minimize the electrical load requirement. If the high-output ammeter indication continues, pull OUT the alternator circuit breaker (located on the right side of the instrument panel) to disconnect the alternator. The aircraft electrical systems will then run on the battery. Turn OFF all unnecessary electrical accessories and land at the nearest airport for service. To re-charge the battery in flight while this condition exists, engage and disengage the alternator circuit breaker. This will maintain battery voltage for safe flight conditions.



Operation Check List and Instructions

**Insufficient Output:** If the ammeter indicates "zero," an alternator failure may have occurred. The alternator circuit breaker, on the right side of the instrument panel, must be in the IN position.

Check to be sure that the Master Switch is ON. To determine if the alternator will function under a heavy electrical load, momentarily turn on the landing light. If no ammeter charge indication is observed, turn off all unneeded electrical systems. Turn the master switch OFF, and proceed to the nearest suitable airport for landing.

The engine in the Yankee is not dependent on the aircraft electrical system for power. Once the engine has been started, it is self-sustaining and is NOT affected by alternator or electrical system malfunctions. All electrically driven accessories may be affected, however, in cases of electrical system malfunctions.

**Engine Failure:** Engine failures are very rare in modern aircraft. Should an engine failure occur, the basic procedures listed below may be a useful guide:

1. Establish normal glide speed of 85 MPH.
2. Pick a suitable landing area and turn toward it for a forced landing.
3. Check master switch ON; magnetos on BOTH; mixture rich; fuel selector ON to fullest tank; carburetor heat ON.

**NOTE:**

*If both sight gauges indicate the presence of fuel, switch tanks since the engine stoppage could be the result of an obstruction in the fuel line.*

4. If the engine does not restart promptly, attention should be shifted to the forced landing procedure.
5. Notify ATC of your location and problem.
6. Turn ignition OFF; Fuel selector OFF; mixture to idle-cut-off; flaps as needed; and the master switch OFF.
7. Complete the landing and secure aircraft. Notify ATC by telephone, of your situation and location if known.

**Windshield Obscuration:** A windshield obscuration caused by ice, moisture condensation or a bird strike may be encountered. Turn cabin heat and defroster full ON to clear the windshield. If obscuration persists, open the canopy, secure the thumbscrew located in the left canopy track, and proceed to the nearest safe airport. A safe landing may be accomplished by using a forward slip to a landing while looking through the opening in the canopy.

**Ground Fire:** Ground fires may be caused by over-priming the engine. Proper starting procedure, outlined on page 11, will help prevent engine-starting fires on the ground.

Should a ground fire develop, the following procedures are suggested:

1. Keep the engine running to ingest the flames into the carburetor. Increasing engine RPM may help.
2. Dispatch ground personnel for fire equipment.
3. When assistance arrives, turn fuel selector valve OFF. Let engine stop due to fuel starvation.
4. If no assistance is available or the fire is beyond control, turn the fuel selector valve OFF, mixture OFF. ABANDON AIRCRAFT.

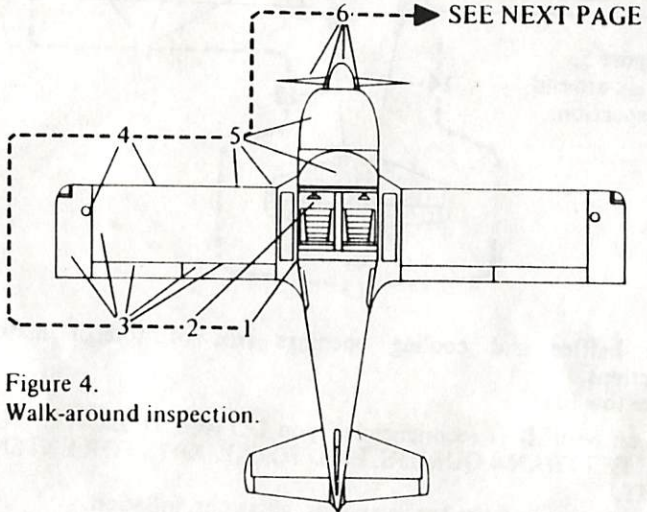

Figure 4. Walk-around inspection.

**Preflight:** The airplane should be given a thorough visual inspection prior to each flight. This procedure is recommended as shown in Figure 4. and 5.

1. Unlock and open canopy.
2. CHECK: Ignition switch OFF, Master switch OFF, mixture control in FULL AFT, IDLE CUT-OFF position. Remove control lock.
3. Drain fuel sample from left wing. Check for flap security. Check ailerons for freedom of movement. Check wing surface and tip for damage. Remove left tie down.
4. Inspect pitot opening for foreign particles. Secure fuel cap for tight seal.
5. Fuel tank vent free of foreign material. Check windshield and canopy for general condition. Inspect landing gear and tires for general condition (wear, cuts, abrasions, leaking brakes, tire inflation).
6. Check propeller and spinner for cracks, nicks and security. Check cowling for damage and security. Check landing light for damage. Check carburetor air passage for obstructions.



**NOTE:**

*When cool and high-humidity conditions exist, do not use partial defrost as windshield may fog rapidly on take-off. Always check defroster position before flight.*

Fresh air ventilation is provided by adjustable vents on the lower cabin side walls, with the air supply being ducted in from inlets in the wing root fairings. Fresh air flow can be increased by opening the canopy one-half to one inch and locking its position with the pilot-side thumbscrew. Maximum ventilation may be obtained by sliding Yankee's canopy halfway at speeds up to 130 MPH. Always leave the thumbscrew disengaged *except* when flying with the canopy partially opened.)

**NOTE:**

*Adjustable and directional "wemac" cooling vents which are located in the lower, forward corners of the canopy to direct fresh air into the upper cabin area, are available as optional equipment.*

**Cabin Description:** Yankee's instrument panel employs a unique "eyebrow" design to shield the windshield from panel reflections during night flights. This eyebrow also houses the panel lights which are turned on and their intensity controlled by a switch-rheostat located just above the throttle. Other panel switches are of the rocker type, combining the convenience of pushbutton operation with the positive action of the toggle.

A cabin dome light for illuminating the baggage compartment and to aid in map reading is located on the overhead of the aft side of the cabin speaker assembly and is controlled by a switch mounted adjacent to the light. It is energized directly from the battery regardless of the master switch position.

Yankee's contoured seats are individually adjustable in a forward/up, rearward/down travel...well suited for both the short and the tall pilot and passenger. The seat bottoms may be flipped up during entry and exit to expose a non-slip tread on the main spar (no more footprints on the seats!).

The center console serves as a seat divider; provides out-of-the-way storage for the microphone; and houses the flap switch and indicator, the trim wheel and indicator, ash tray, fuel selector valve, and the inboard seat belt holders. The fuel quantity sight gauges are located on the side walls forward of the seats, and are individually lighted by lamps which are controlled by the instrument light switch-rheostat.

Yankee's baggage compartment (or optional child's seat) is accessible during flight to either the pilot or passenger. It is lighted by a dome light incorporated into the speaker fixture. The baggage compartment is certified for 100 pounds capacity (90 pounds with the child's seat installed), and includes a hat shelf for storing light objects.

In many ways, Yankee is a contradiction. It is extremely simple to understand, to fly and to maintain. Yet, its systems are quite sophisticated in their approach to safety and reliability. Yankee is powered by an economical 108 horsepower engine; yet it gives better performance than aircraft boasting far more power. And Yankee has obviously been built to stress performance...but has preserved the comfort and convenience features *without compromise.*

**In-flight Engine Fires:** In-flight engine fires in today's modern aircraft are extremely rare. However, the following procedures are suggested should one occur:

1. Fuel selector: OFF.
2. Mixture: Idle-Cut/OFF.
3. Master switch: OFF.
4. Cabin heat control: OFF.
5. Establish a maximum safe rate of descent. *Increasing speed may blow the fire out.*
6. Side slip maneuvers may be used, as necessary, to direct flames away from cabin area.
7. Select a suitable field for a forced landing.
8. Notify ATC if possible and complete the forced landing. *Do not attempt to restart the engine.*

**In-flight Electrical Fires:** Indication of in-flight electrical fires may be wisps of smoke or the smell of hot or burning insulation. Should an electrical fire develop, the following procedures are suggested:

1. Master Switch: OFF.
2. All electrical switches: OFF.
3. Ignition switch: ON.
4. Cabin air vents: OFF. (If ventilation is necessary, the cabin air vent may be opened for brief periods. Under these conditions the canopy may be cracked or opened as required.)
5. Proceed to nearest suitable airport for landing.

If electrical power is necessary for safety of flight under the above conditions, the following procedures are recommended:

1. Disengage and isolate each power circuit.
2. Master Switch: ON.
3. Engage each electrical circuit separately. Allow sufficient time to analyze for faulty operation.
4. Analyze each circuit separately until the malfunctioning system is detected. **DO NOT** disengage circuits that are determined to be functioning properly.
5. Disengage faulty circuit and report any problems to the FAA controlling agency.
6. If necessary, proceed to nearest suitable airport and land.

**Blown Tires:** If a landing is to be made with a blown tire, the following procedures are suggested:

**Main Tires**

1. Plan your approach with a slightly long final for a slow rate of descent.
2. Approach at the slowest safe speed for the conditions. A power-on approach is recommended.
3. Touch down on the good tire only. Use power to cushion the landing (this is the time for a "greaser"). Allow the nose wheel to touch down.
4. Hold the blown tire off the ground with aileron as long as possible.
5. After the blown tire has touched down, allow the aircraft to roll to a stop, lightly and intermittently applying the brakes on the "good" tire to maintain directional control.



### Nose Tire

1. Plan a slightly long, power-on approach for a slow rate of descent.
2. Touch down in a slightly nose-high attitude at a safe air speed.
3. Gently lower the nose wheel as the air speed decreases to the point at which elevator control is lost, thereby averting the hard impact when the nose "falls through."
4. After the nose wheel touches down, allow the aircraft to roll to a stop without the use of brakes. Use of brakes places additional weight on the defective nose gear tire.

**Icing Conditions:** Carburetor ice may be encountered at any time. The *first* indication of carburetor ice in the Yankee should be a slight drop in engine RPM. Slight engine roughness may or may not accompany this engine RPM drop. If carburetor icing is suspected, the following procedures are suggested:

1. *Slowly* apply *full* carburetor heat. Engine roughness may then occur due to an overrich mixture or water from the melting ice.
2. Continuous engine operation with carburetor heat ON is *not* recommended due to the decrease in engine efficiency.

Flying in known icing conditions is prohibited by FAA regulations. However, should wing icing occur the following procedures are suggested:

1. Turn pitot heat ON.
2. Turn windshield defroster full ON.
3. If IFR or under control of an in-flight ground facility, notify them of the condition and request assistance. A change of altitude, if possible, or reversing course to fly out of the icing conditions may be desirable.
4. Pilot technique is important in this situation:
  - a. Increase and decrease engine RPM to keep propeller clear of ice.
  - b. Increase airspeed if possible. This technique reduces angle of attack exposing less surface area for ice accumulation.
  - c. Do not extend flaps. A clean configuration will expose less surface to ice and will prevent a change in air flow over the tail surfaces.
5. Monitor engine RPM for any indication of carburetor ice. (Refer to carburetor ice procedures.)
6. Plan a landing at the first suitable airport. The following procedures are suggested:
  - a. If the windshield is obstructed, the canopy may be opened to improve visibility. A forward slip may be helpful.
  - b. Remember that ice accumulation increases wing loading, decreases performance, decreases range and increases stall speeds. When landing, plan a slightly higher than normal air speed during landing approach. Guard against increased stall speed created by the above mentioned conditions. Touch down in a level altitude.

### REMEMBER:

*Flying in icing conditions is NOT APPROVED!*

### NOTE:

*Check fuel sight gauges while in level, balanced flight to avoid mis-reading fuel quantity indications.*

**Landing Gear:** Yankee's FACE SAVER<sup>®</sup> main landing gear struts are of tough, laminated fiberglass to achieve outstanding shock absorption and damping. Yankee's unusually wide stance (99" between the main wheels) imparts extraordinary ground stability and optimizes the performance of differential-braking steering at speeds below the rudder effectiveness threshold. The nose gear is free-castering to 90° on either side of the centerline, which gives Yankee outstanding agility and maneuverability on the ground.

**Brakes:** Yankee's brakes are toe-operated, single-disc hydraulic systems with integral parking brakes. The parking brake is set by pressing the toe brakes while simultaneously pulling the parking brake knob (at the right side of the panel). To release, push the parking brake knob in and press the toe brakes firmly. *Parking brakes are operated from the left side only.*

**Electrical System:** Yankee's electrical system (Fig. 3) is extremely simple, yet is quite sophisticated in its approach to reliability. It employs a brushless 14-volt, 40-amp alternator which inherently eliminates a major source of electrical noise (i.e., the brushes in traditional generators), and which maintains proper bus voltage regardless of engine speed. Internal power diodes in the alternator deliver DC power direct to the main bus through a 40-amp circuit breaker. An external transistorized voltage regulator controls the alternator's output voltage, and *automatically* increases the battery charging voltage at low ambient temperatures.

Yankee's 25-ampere-hour battery, located on the upper right firewall in the engine compartment, is connected to the main bus through the battery solenoid when the master switch is in the ON position. The master switch also energizes the voltage regulator, the battery solenoid, and all electrical loads connected to the main bus. With the master switch in the OFF position, the alternator is de-energized, and all electrical loads *except the cabin dome light* are de-energized. Note that it is possible to disconnect the alternator from the bus by manually pulling the 40-amp circuit breaker, yet continue to feed the bus loads from the battery by leaving the master switch in the ON position.

Fuses and circuit breakers for electrical systems are located on the lower right side of the instrument panel, and spare fuses are bracket-mounted in the right side of the glove compartment. All electrical switches for lighting and accessories are located at the right side of the pilot's control wheel.

Yankee's dual-magneto ignition system is completely independent of the aircraft electrical system, and will continue to operate during any electrical emergency.

**Heating and Ventilating:** Cabin heat and defroster air are supplied by a heat exchanger on the engine exhaust system. This system heats a continuous flow of fresh air, and provides heating and defrosting by diverting the desired portion of that continuous supply into the cabin and bypassing the balance directly overboard. To obtain defrost air, pull out the cabin heat control (on the right side of the instrument panel), and slide open the defroster vent near the lower left edge of the windshield.



## Care of the Airplane

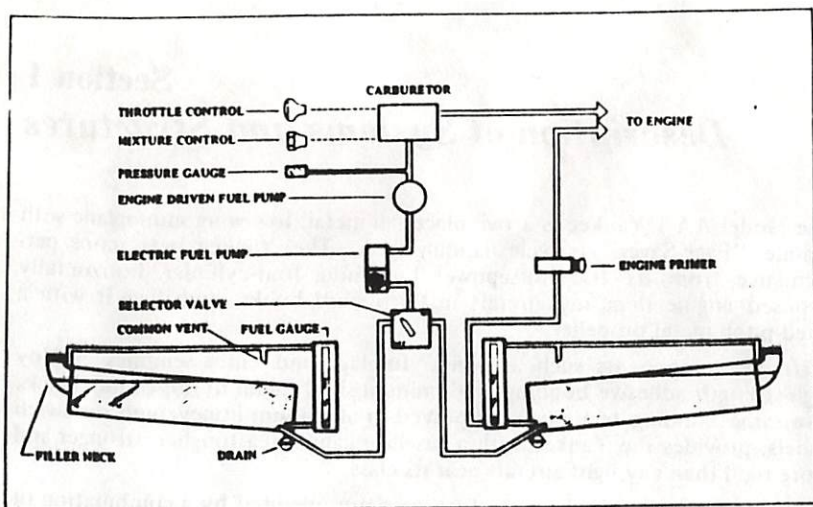

Figure 2. Schematic of Yankee's Fuel System.

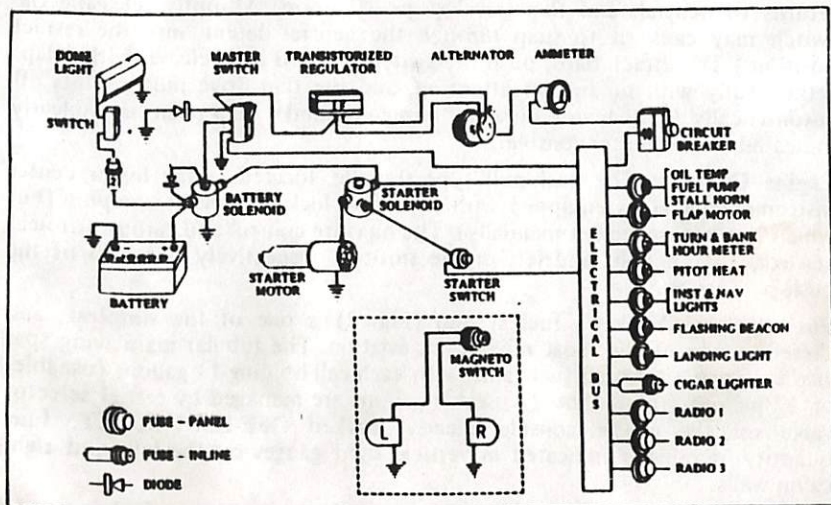

Figure 3. Schematic of Yankee's Electrical System.

Proper maintenance and general attention to detail will assure a long life and maximum reliability for your Yankee...and the Yankee has made it surprisingly easy, fast and economical.

**Exterior Care:** The painted surfaces of the Yankee have a long-lasting, all-weather finish and should require no buffing or rubbing out in normal conditions. However, it is desirable to wax and polish your Yankee to preserve the outstanding exterior finish. It is recommended that wax or polish operations be delayed at *least 60 days after date of certification* to allow proper curing of the paint.

The paint can be kept bright simply by washing with water and mild soap. Avoid abrasive or harsh detergents. Rinse with clear water and dry with terry cloth towels or chamois. Oil and grease spots may be removed with kerosene or mineral spirits.

If you choose to wax your airplane, use a good automotive-type wax applied as directed. The use of wax in areas subject to high abrasion, such as leading edges of wings and tail surfaces, propeller spinner and blades, is recommended.

**Windshield, Canopy and Window Care:** It is recommended that you keep the plexiglass in the canopy, windshield and cabin windows clean and unscratched. The following procedures are recommended:

1. If large deposits of mud and/or dirt have accumulated on the plexiglass, flush with clean water. Rubbing with your hand is recommended to dislodge excess dirt and mud without scratching the plexiglass.
2. Wash with soap and water. Use a sponge or heavy wadding of soft cloth. Do NOT rub, as the abrasive action in the dirt and mud residue will cause fine scratches in the surface.
3. Grease and oil spots may be removed with a soft cloth soaked in kerosene.
4. After cleaning, wax the plexiglass surface with a thin coat of hard polishing wax. Buff with a soft cloth.
5. If a severe scratch or marring occurs, jeweler's rouge is recommended. Follow directions, rub out scratch, smooth, apply wax and buff.

**REMEMBER! NEVER use gasoline, benzine, alcohol, acetone, carbon tetrachloride, fire extinguisher fluid, anti-ice fluid, laquer thinner or glass cleaner to clean the plastic. These materials will damage the plastic and may cause severe crazing.**

**Propeller Care:** Damage from foreign objects, sometime referred to as "nicks," may appear in the leading edges of the propeller from time to time. It is vital that these nicks be corrected as quickly as possible. Such minor damage may cause stress concentrations and result in cracks forming in the propeller. Keep the blades clean and free of dirt or grass buildup. This type of



## Description of Systems and Structures

foreign material on the propeller may cause an imbalance and accompanying vibration. We recommend cleaning agents such as carbon tetrachloride or mineral spirits for propeller care.

**Tire Service:** All tires and wheels are balanced at the factory prior to original installation. A similar relationship of the tire, tube and wheel should be maintained on your Yankee. If vibration is encountered, it may be due to out-of-balance conditions. When wheel, tire *or* tube is replaced due to wear, it is recommended that they be re-balanced.

**Battery Service:** Easy access to the battery is through the oil access door on the top right side of the cowling. The battery is equipped with an overboard manifold vent, thereby eliminating the need for the battery box to be vented. The battery in your Yankee is rated at 12 volt, 25 ampere-hours. It should be inspected periodically for proper fluid level. If the fluid level is found to be low, fill as recommended by the battery manufacturer. **DO NOT** fill above the visible battery baffle plates.

**Brake Service:** The Yankee Service Manual outlines procedures to use in the case of soft or ineffective brakes.

**Fuel and Oil Requirements:** Aviation gasoline, grade 80/87 octane, is the standard fuel recommended by AAC and the engine manufacturer for the Yankee. Do not use lower octane fuel for it may cause serious engine damage. Lycoming's engine warranty is invalidated by the use of low grade fuel! The Lycoming O-235-C2C engines have an oil capacity of 6 quarts. Operational use is limited to an oil level of 4 quarts for local flight and 6 quarts for extended flight. *Absolute minimum safe quantity is 2 quarts.*

Lycoming recommends time between oil changes at 50 hours. If conditions dictate, a more frequent oil change may be required (refer to Lycoming engine manual for specifics). The following oil grades are recommended:

Above 60° F	SAE 50
30° to 90° F	SAE 40
0° to 70° F	SAE 30
Below 10° F	SAE 20

**Engine Roughness:** If a rough-running engine is encountered, it may be for any one of the following reasons:

1. Lead or oil fouled spark plugs.
2. Incorrect fuel/air mixture.
3. Partial ignition failure.
4. Incorrect use of carburetor heat.

Spark plugs may become oil-fouled during taxiing, prolonged power-off descents, or cruising with an improper fuel-to-air mixture. The majority of engine roughness encountered is due to fouled spark plugs. This may be eliminated by increasing engine power to 75%, leaning the engine to the correct fuel/air ratio for the altitude and burning the plugs clean. Prolonged engine roughness may be due to partial ignition failure. An ignition failure or partial failure is checked by momentarily selecting the left and right ignition on the key-operated switch. If either position produces a significant increase in engine roughness, a partial ignition failure is likely. *The Yankee is equipped with two totally independent ignition systems to compensate for such*

The Model AA-1 Yankee is a two-place, all-metal, low-wing monoplane with unique "Face-Saver" tricycle landing gear. The Yankee gets more performance from its 108 horsepower Lycoming four-cylinder, horizontally opposed engine than any aircraft in the record books...and does it with a fixed-pitch metal propeller.

Airframe components such as wings, fuselage and tail assemblies employ high-strength adhesive bonding of aluminum sheet metal to ribs or bulkheads. The same bonding technique, employed in aluminum honeycomb sandwich panels, provides the Yankee with a fuselage cabin area tougher, stronger and more rigid than any light aircraft near its class.

**Flight Controls:** Yankee's control surfaces are operated by a combination of torque tubes and conventional cable systems. The right elevator includes an adjustable trim tab, controlled by a trim wheel on the center console. Ground-adjustable tabs on the rudder and ailerons provide a simple means for verniering directional and lateral trim.

Electrically operated flaps offer a full range of settings by means of a spring-loaded, two-position switch. This flap actuator switch is held down until the flap position indicator shows the desired flap angle; when released, it returns to neutral, and flap travel stops. (Caution: Abruptly releasing the switch may cause it to snap *through* the neutral detent, into the retract position.) To retract flaps, push the switch forward and release it; the flaps retract fully with no further attention, and the flap drive motor shuts off automatically (very handy on a full-flap go-around). Flap position is clearly indicated on the center console.

**Engine Controls:** The push-pull type throttle, located in the lower center instrument panel, is equipped with a friction lock to prevent creeping (but which can be overridden manually). The mixture control and carburetor heat control, to the right and left of the throttle, respectively, are also of the push-pull design.

**Fuel System:** Yankee's fuel system (Fig. 2) is one of the simplest, and therefore one of the most reliable, in aviation. The tubular main wing spar also serves as a two-cell fuel tank, with each cell holding 11 gallons (usable) or 12 gallons (total). The 22 useable gallons are managed by a fuel selector valve on the center console, clearly marked OFF-LEFT-RIGHT. Fuel quantity is reliably indicated in vertical sight gauges on the left and right cabin walls.

An auxiliary electric fuel pump supplements the engine-driven fuel pump to provide fuel pressure redundancy during low-altitude operation, such as during take-off and landing. Fuel pressure is indicated on a gauge in the engine instrument cluster, located to the right of the radio section of the instrument panel. And each wing tank has its own quick drain located on the bottom inboard trailing edge of each wing.



matters. Place the key-operated ignition switch in the BOTH position--there is NO immediate danger. Proceed and land at the next convenient airport.

Improper use of carburetor heat also may induce engine roughness. Abrupt application of carburetor heat when cruising above 500 MSL may result in momentary engine roughness. This condition is caused by warm air being fed into the carburetor. Warm air is less dense and tends to upset the fuel/air ratio, thus causing an overrich mixture condition. Returning the carburetor heat to OFF will tend to correct this problem. It may be necessary, from time to time, to fly with partial carburetor heat. Adjust mixture for smooth operation.

*Flying with partial carburetor heat is not recommended unless the aircraft has a functioning carburetor air temperature gauge installed.*

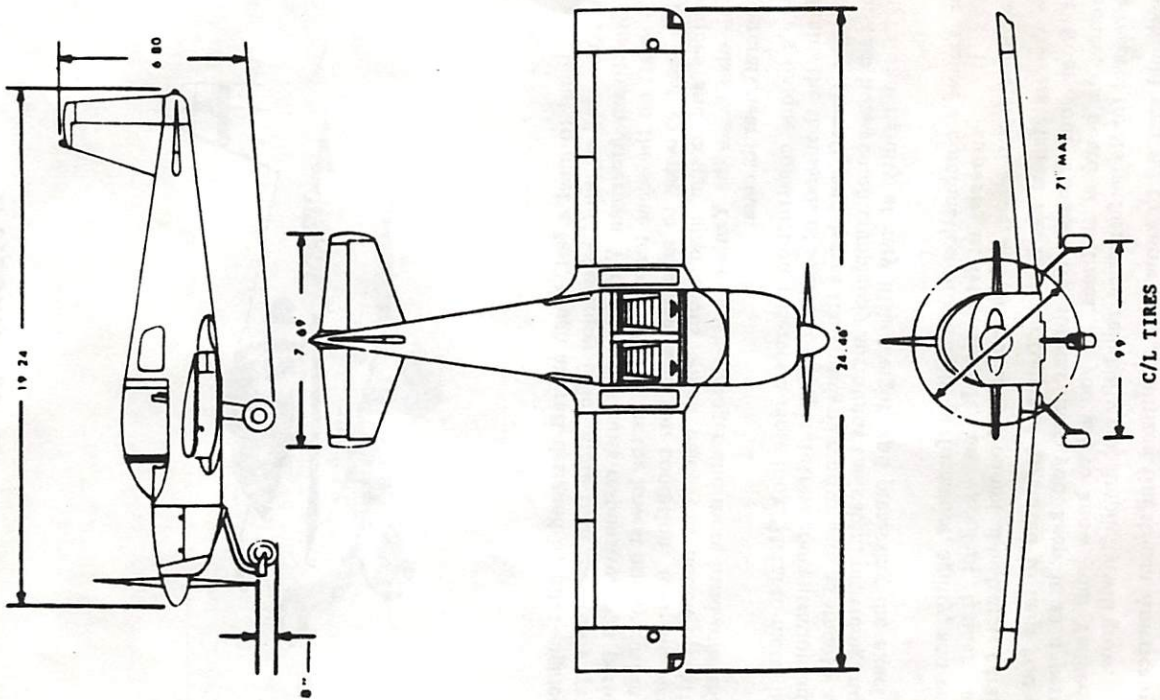

Figure 1. Yankee's principal dimensions.



## WARRANTY

GULFSTREAM AMERICAN CORPORATION (herein GULFSTREAM AMERICAN) warrants each new aircraft and part thereof manufactured by it, together with all new aircraft equipment and accessories bearing the name "GULFSTREAM AMERICAN CORPORATION," to be free from defects in material and workmanship under normal use and service, but extends no warranty of any kind, expressed or implied, to any items manufactured by GULFSTREAM AMERICAN, or not so bearing its name; whether incorporated into or installed in the aircraft, except that the workmanship involved in installing such items is warranted to be without defect. The obligation of GULFSTREAM AMERICAN under this warranty is limited to replacement, or repair, at the option of GULFSTREAM AMERICAN, of any such aircraft, or any part or accessory which shall within six (6) months of operation be found defective. Such aircraft, part or accessory is to be returned to a GULFSTREAM AMERICAN DEALER upon which examination by GULFSTREAM AMERICAN, shall disclose to its reasonable satisfaction to have been thus defective. This warranty shall not in any way apply to or cover any products which are in GULFSTREAM AMERICAN's opinion damaged as a result of being in any manner altered or repaired outside of the factory of GULFSTREAM AMERICAN or that shall have been subject to misuse or negligence.

GULFSTREAM AMERICAN makes no warranty whatsoever with respect to engines, radios, propellers, ignition apparatus, starting devices, generators, batteries, or other trade accessories, inasmuch as such products are generally warranted separately by their respective manufacturers.

"THESE WARRANTY PROVISIONS ARE EXPRESSLY IN LIEU OF ALL OTHER WARRANTIES, EXPRESSED, STATUTORY OR IMPLIED IN FACT OR BY LAW, INCLUDING ANY IMPLIED WARRANTY OF MERCHANTABILITY OR FITNESS FOR A PARTICULAR PURPOSE AND OF ANY OTHER OBLIGATION OR LIABILITY ON THE PART OF GULFSTREAM AMERICAN, EXPRESSED OR IMPLIED, OF ANY NATURE WHATSOEVER. GULFSTREAM AMERICAN NEITHER ASSUMES NOR AUTHORIZES ANY OTHER PERSON OR BUSINESS ORGANIZATION TO ASSUME FOR IT ANY OTHER WARRANTY OR LIABILITY IN CONNECTION WITH THE SALE, USE OR OPERATION OF ITS PRODUCTS."

IMMEDIATELY ON COMMENCING FIRST USE OF AN AIRCRAFT, A WARRANTY VALIDATION CARD MUST BE FILLED OUT AND MAILED TO THE ATTENTION OF THE CUSTOMER SERVICE MANAGER, COMMERCIAL LIGHT AIRCRAFT, P.O. BOX 2206, SAVANNAH, GEORGIA 31402. NO WARRANTY CLAIMS WILL BE HONORED IF THIS CARD IS NOT ON FILE AT THE FACTORY.

## Welcome Aboard!



You are about to meet a fast, tough aircraft designed by pilot-engineers for pilots... the kind of pilots who enjoy flying more than they enjoy spending. The Gulfstream American Yankee is the most responsive, high performing light aircraft on the scene today; yet it offers the lowest hourly cost in flight, and the least expense to maintain it in top condition. And the materials, techniques and design innovations which made this double-breakthrough possible also made the Yankee much stronger and more handsome than any light aircraft near its class.

Yankee's unique construction deserves a close look. Metal-to-metal bonding eliminates the thousands of sources of drag and stress concentration built into other light aircraft, and leaves the aerodynamic surfaces as smooth as glass. Aluminum honeycomb completely surrounds the cabin, providing incredible strength and rigidity at very little weight, and preserving the exact design contours.

Your Yankee's combination of strength, performance, agility, and economy makes it a superb utility aircraft, an excellent trainer, a great cross-country/sport plane, and an unusually economical instrument trainer.

Your Owners Manual has been written and organized to help you get the most from your Yankee. We suggest that you keep it as a permanent reference, on board at all times. As you get to know your Yankee better, your respect for its performance, reliability and simplicity will grow.

You should also get to know your authorized Gulfstream American Dealer. He can provide the rapid, expert service that will keep your Yankee young for many, many years. His factory-trained service people are professionals.

So — Welcome Aboard! We hope that your spirit of adventure gets the same boost that ours did when we first flew Yankee.



Owner \_\_\_\_\_ Registration No. N \_\_\_\_\_

Performance/Specifications: Model AA-1 Yankee		Normal	Utility
GROSS WEIGHT . . . . .		1500 lbs	1330 lbs
SPEED:	Top Speed at Sea Level . . . . .	144 MPH	145 MPH
	Cruise, 75% Power at 8,000 ft . . . . .	134 MPH	137 MPH
	Cruise, 65% Power at 8,000 ft . . . . .	123 MPH	127 MPH
RANGE:	Cruise, 75% Power at 8,000 ft . . . . .	466 mi	477 mi
	22.0 Gallons, No Reserve . . . . .	3.48 hrs	3.48 hrs
	Cruise, 65% Power at 8,000 ft . . . . .	501 mi	517 mi
	22.0 Gallons, No Reserve . . . . .	4.07 hrs	4.07 hrs
	Optimum Range at 10,000 ft . . . . .	516 mi	547 mi
	22.0 Gallons, No Reserve . . . . .	4.52 hrs	4.52 hrs
RATE OF CLIMB AT SEA LEVEL . . . . .		710 fpm	905 fpm
SERVICE CEILING . . . . .		11,000 ft	13,150 ft
TAKE OFF:	Ground Roll . . . . .	900 ft	660 ft
	Total Distance Over 50-ft Obstacle . . . . .	1615 ft	1215 ft
LANDING:	Ground Roll . . . . .	490 ft	380 ft
	Total Distance Over 50-ft Obstacle . . . . .	1240 ft	1140 ft
WING LOADING . . . . .		15.3 lb/sq ft	13.6 lb/sq ft
POWER LOADING . . . . .		13.9 lb/bhp	12.3 lb/bhp
BAGGAGE . . . . .		100 lbs	
FUEL CAPACITY, TOTAL . . . . .		24 gal	
OIL CAPACITY, TOTAL . . . . .		6 qts	
PROPELLER: McCauley Fixed Pitch Diameter . . . . .		71 inches	
ENGINE: Lycoming/108 HP at 2600 RPM . . . . .		0-235-C2C	

NOTE: Speed performance data is with wheel fairings. Subtract 2 MPH for cruise without wheel fairings. Range and endurance figures do not include take off and climb allowance.

### Table of Contents

I. Description of Systems & Structures . . . . .	5	V. Performance Charts . . . . .	24
II. Operation Check List & Instructions . . . . .	9	VI. Emergency Procedures . . . . .	27
III. Operating Procedures . . . . .	14	VII. Care of the Airplane . . . . .	31
IV. Operating Limitations . . . . .	19	WARRANTY . . . . .	33
		Service Requirements . . . . .	35

### SERVICE REQUIREMENTS

Fuel:	Aviation grade	80/87 minimum grade	
	Tank capacity (2)	12 gallons	
Engine Oil:	Aviation Grade		
	* Recommended Grade Oil		
Average Ambient Air	Mineral Grade	Ashless Dispersant	
	Above 60° F	SAE 50	SAE 40 or SAE 50
	30° to 90° F	SAE 40	SAE 40
	0° to 70° F	SAE 30	SAE 40 or SAE 30
Below 10° F	SAE 20	SAE 30	
Oil Sump Capacity . . . . .		6 U. S. quarts	
Minimum Safe Quantity in Sump . . . . .		2 U. S. quarts	
Hydraulic Fluid:	MIL-H-5606		
Tire Inflation:			
	Nose Wheel	22PSI	5.00 x 5 Tire
	Main Wheels (Sm.)	26PSI	15-6.00 x 6 tires
	Main Wheels (Lg.)	19PSI	6.00 x 6 tires

\* Refer to latest revision of Lycoming Service Instruction No. 1014.

Fully Illustrated Parts Catalogs and Service Manuals are obtainable through authorized Dealers of Gulfstream American Corporation.



**CHECK LIST - MODEL AA - 1 YANKEE**

- |  |                               |
|--|-------------------------------|
| <b>BEFORE STARTING</b>   | 6. Controls - CHECK           |
| 1. PREFLIGHT - Fuel, Oil, Prop,<br>Tires, Aircraft General Condition | 7. Engine Inst. - CHECK       |
| 2. Seats and Belts: ADJUSTED   | 8. Flight Inst. - SET & CHECK |
| 3. Brakes - ON   | 9. Canopy - CHECK             |
| 4. Controls - FREE   | <b>TAKE-OFF</b>               |
| 5. FUEL - Fulllest Tank  | 1. Aux. Pump - ON             |
| <b>STARTING ENGINE</b>   | 2. FULL THROTTLE              |
| 1. Primer - AS REQUIRED  | 3. Raise Nose - 65 to 70 MPH  |
| 2. Mixture - RICH  | <b>CLIMB</b>                  |
| 3. Throttle - CLOSED   | 1. FULL THROTTLE              |
| 4. Carb. Heat - OFF  | 2. Normal - 95 MPH            |
| 5. Master Switch - ON  | <b>CRUISE</b>                 |
| 6. Aux. Pump - ON (.5 to 8psi)                                       | 1. Power - 2100 to 2600 RPM   |
| Aux. Pump - OFF  | 2. Aux. Pump - OFF            |
| 7. CLEAR PROP  | 3. Lean - AS REQUIRED         |
| 8. Ignition Switch - ON LEFT   | 4. Fuel Quantity - CHECK      |
| 9. Starter - PRESS   | <b>BEFORE LANDING</b>         |
| 10. Ignition Switch - ON BOTH  | 1. FUEL - Fulllest Tank       |
| 11. Oil Pressure - CHECK   | 2. Aux. Pump - ON             |
| <b>ENGINE RUNUP</b>  | 3. Mixture - RICH             |
| 1. Brakes - ON   | 4. Carb. Heat - AS REQUIRED   |
| 2. Throttle - SET (1800 RPM)   | 5. Flaps - AS REQUIRED        |
| 3. Engine Inst. - CHECK  | (Max. 100 MPH)                |
| 4. Magneto - CHECK (125 RPM ea.)<br>(Max. Difference 50 RPM)         | 6. Approach - 85 MPH          |
| 5. Carb. Heat - CHECK  | <b>AFTER LANDING</b>          |
| <b>BEFORE TAKE-OFF</b>   | 1. Flaps - UP                 |
| 1. Flaps - CHECK OPERATION   | 2. Carb. Heat - OFF           |
| Flaps - UP   | 3. Aux. Pump - OFF            |
| 2. Trim - SET  | <b>SHUT DOWN</b>              |
| 3. Primer - LOCKED   | 1. Elec. Equip. - OFF         |
| 4. Mixture - RICH  | 2. Mixture - IDLE CUTOFF      |
| 5. Carb Heat - OFF   | 3. Magnetos - OFF             |
|  | 4. Master Switch - OFF        |

**OWNER'S MANUAL**

**MODEL AA-1  
YANKEE**



**Gulfstream American**

Gulfstream American Corporation

P.O. Box 2206 Savannah, Georgia 31402



**Gulfstream American**



Owner \_\_\_\_\_ Registration No. N \_\_\_\_\_

Performance/Specifications: Model AA-1 Yankee		Normal	Utility
GROSS WEIGHT		1500 lbs	1330 lbs
SPEED:	Top Speed at Sea Level	144 MPH	145 MPH
	Cruise, 75% Power at 8,000 ft	134 MPH	137 MPH
	Cruise, 65% Power at 8,000 ft	123 MPH	127 MPH
RANGE:	Cruise, 75% Power at 8,000 ft	466 mi	477 mi
	22.0 Gallons, No Reserve	3.48 hrs	3.48 hrs
	Cruise, 65% Power at 8,000 ft	501 mi	517 mi
	22.0 Gallons, No Reserve	4.07 hrs	4.07 hrs
	Optimum Range at 10,000 ft	516 mi	547 mi
	22.0 Gallons, No Reserve	4.52 hrs	4.52 hrs
RATE OF CLIMB AT SEA LEVEL		710 fpm	905 fpm
SERVICE CEILING		11,000 ft	13,150 ft
TAKE OFF:	Ground Roll	900 ft	660 ft
	Total Distance Over 50-ft Obstacle	1615 ft	1215 ft
LANDING:	Ground Roll	490 ft	380 ft
	Total Distance Over 50-ft Obstacle	1240 ft	1140 ft
WING LOADING		15.3 lb/sq ft	13.6 lb/sq ft
POWER LOADING		13.9 lb/bhp	12.3 lb/bhp
BAGGAGE		100 lbs	
FUEL CAPACITY, TOTAL		24 gal	
OIL CAPACITY, TOTAL		6 qts	
PROPELLER: McCauley Fixed Pitch Diameter		71 inches	
ENGINE: Lycoming/108 HP at 2600 RPM		3-235-C2C	

NOTE: Speed performance data is with wheel fairings. Subtract 2 MPH for cruise without wheel fairings. Range and endurance figures do not include take off and climb allowance.

#### Table of Contents

I. Description of Systems & Structures	5	V. Performance Charts	24
II. Operation Check List & Instructions	9	VI. Emergency Procedures	27
III. Operating Procedures	14	VII. Care of the Airplane	31
IV. Operating Limitations	19	WARRANTY	33
		Service Requirements	35

#### SERVICE REQUIREMENTS

##### Fuel:

Aviation grade	80/87 minimum grade
Tank capacity (2)	12 gallons

##### Engine Oil:

Aviation Grade  
\* Recommended Grade Oil

Average Ambient Air	Mineral Grade	Ashless Dispersant
Above 60° F	SAE 50	SAE 40 or SAE 50
30° to 90° F	SAE 40	SAE 40
0° to 70° F	SAE 30	SAE 40 or SAE 30
Below 10° F	SAE 20	SAE 30
Oil Sump Capacity	6 U. S. quarts	
Minimum Safe Quantity in Sump	2 U. S. quarts	

##### Hydraulic Fluid:

MIL-H-5606

##### Tire Inflation:

Nose Wheel	22PSI	5.00 x 5 Tire
Main Wheels (Sm.)	26PSI	15-6.00 x 6 tires
Main Wheels (Lg.)	19PSI	6.00 x 6 tires

\* Refer to latest revision of Lycoming Service Instruction No. 1014.

Fully Illustrated Parts Catalogs and Service Manuals are obtainable through authorized Dealers of Gulfstream American Corporation.



CHECK LIST - MODEL AA-1 YANKEE

**BEFORE STARTING**

1. PREFLIGHT - Fuel, Oil, Prop, Tires, Aircraft General Condition
2. Seats and Belts: ADJUSTED
3. Brakes - ON
4. Controls - FREE
5. FUEL - Full Tank

**STARTING ENGINE**

1. Primer - AS REQUIRED
2. Mixture - RICH
3. Throttle - CLOSED
4. Carb. Heat - OFF
5. Master Switch - ON
6. Aux. Pump - ON (.5 to 8psi)  
Aux. Pump - OFF
7. CLEAR PROP
8. Ignition Switch - ON LEFT
9. Starter - PRESS
10. Ignition Switch - ON BOTH
11. Oil Pressure - CHECK

**ENGINE RUNUP**

1. Brakes - ON
2. Throttle - SET (1800 RPM)
3. Engine Inst. - CHECK
4. Magneto - CHECK (125 RPM ea.)  
(Max. Difference 50 RPM)
5. Carb. Heat - CHECK

**BEFORE TAKE-OFF**

1. Flaps - CHECK OPERATION  
Flaps - UP
2. Trim - SET
3. Primer - LOCKED
4. Mixture - RICH
5. Carb Heat - OFF

6. Controls - CHECK.
7. Engine Inst. - CHECK
8. Flight Inst. - SET & CHECK
9. Canopy - CHECK

**TAKE-OFF**

1. Aux. Pump - ON
2. FULL THROTTLE
3. Raise Nose - 65 to 70 MPH  
**CLIMB**

1. FULL THROTTLE
2. Normal - 95 MPH

**CRUISE**

1. Power - 2100 to 2600 RPM
2. Aux. Pump - OFF
3. Lean - AS REQUIRED
4. Fuel Quantity - CHECK

**BEFORE LANDING**

1. FUEL - Full Tank
2. Aux. Pump - ON
3. Mixture - RICH
4. Carb. Heat - AS REQUIRED
5. Flaps - AS REQUIRED  
(Max. 100 MPH)
6. Approach - 85 MPH

**AFTER LANDING**

1. Flaps - UP
2. Carb. Heat - OFF
3. Aux. Pump - OFF

**SHUT DOWN**

1. Elec. Equip. - OFF
2. Mixture - IDLE CUTOFF
3. Magnetos - OFF
4. Master Switch - OFF

**OWNER'S MANUAL**

**MODEL AA-1**

**YANKEE**



**Gulfstream American**

Gulfstream American Corporation

P.O. Box 2206 Savannah, Georgia 31402



**Gulfstream American**